

## Nuclear Radiation Sensing Field Effect Transistor (NürFET) Dosimeter in Reader Circuit Mode Data Sheet

**200 nm SiO<sub>2</sub>- Six Pad NürFET (Product ID: SO-200-ID#1-V1)  
Dose Range from 1 Gy to 2500 Gy**

### General Information

The NÜRDAM NÜRFET chip, enclosed in an 8-lead ceramic DIP side braze package. This component includes two NÜRFETs, as illustrated in Figure 1 and detailed in Table 1. The NürFETs exhibit distinct characteristics, with a W/L ratio of 400µm/60µm (R1) and 300 µm/50µm (R2). The NürFETs' gate oxide thickness is 200nm. Source/bulk tied together for NürFET-R1, while remaining terminals both for R1 and R2 tied separate.

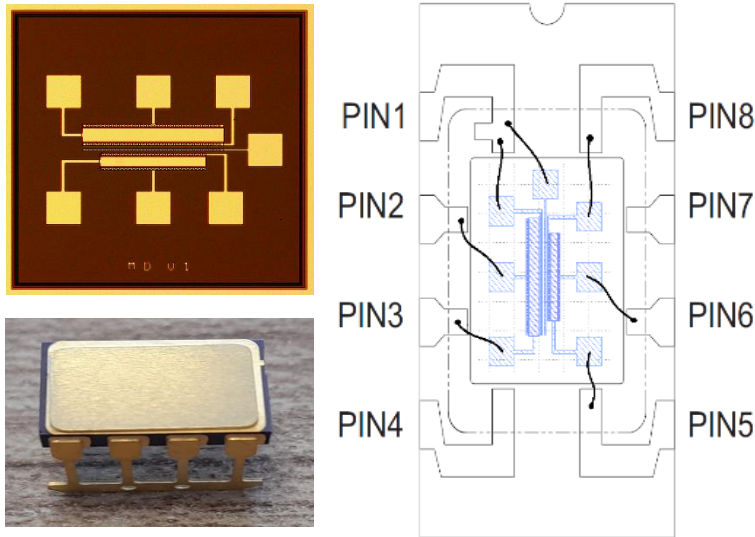

**Table 1: Pin-Out Description**

PIN No	Description
PIN 1	- Source/Bulk of R1 - Bulk for R2
PIN 2	Drain of R1
PIN 3	Gate of R1
PIN 4	No Connection
PIN 5	Gate of R2
PIN 6	Drain of R2
PIN 7	No Connection
PIN 8	Source of R2

**Figure 1: NürFETs and pin-out drawing.**

### Absolute Maximum Ratings

**Table 2: Absolute Maximum ratings of the NürFETs**

Characteristics	Specification	Unit	Remarks
Drain-Source Voltage, $V_{ds}$	- 5 to - 20	Volt	Ideally -10 V
Gate-Source Voltage, $V_{gs}$	$\pm 40$	Volt	
Drain-Gate Voltage, $V_{ds}$	$\pm 40$	Volt	
Drain Current, $I_{ds}$	- 1	mAmper	Continuous
Temperature Operation Range*, $T_{op}$	- 40 to + 110	Celcius (°C)	

\* No dew condensation: In high humidity environments, if there is a temperature difference between a product and its surroundings, condensation may form on the product's surface. This condensation can lead to degradation in its characteristics and reliability.

## Operations

### Irradiation Detection Configuration

For optimal performance in this operating mode, it is advised to ensure that all terminals of the NürFET are grounded. If you seek alternative biasing options, please reach out with us.

### Read-Out Configuration

The NürFET can be read at flexible intervals, determined by the specific application. The time span between readings can range from seconds to days or even weeks. Refer to Figure 2 for the Reader Circuit (RC) utilized to read the NürFET

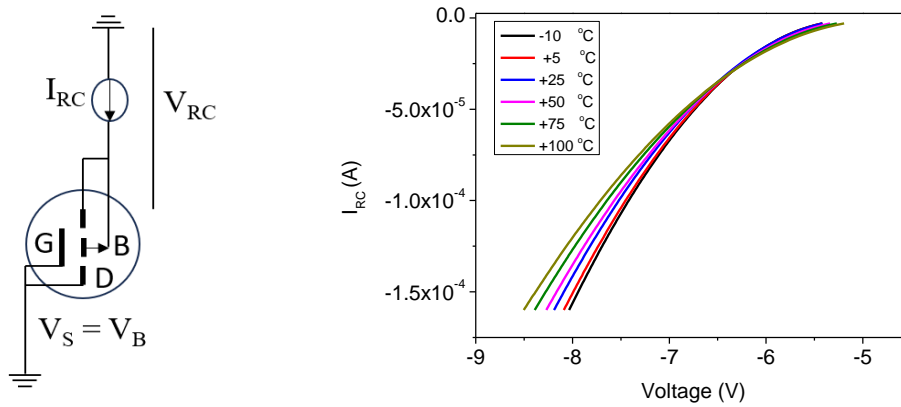

**Figure 2:** Reader Circuit (RC) configuration and RC-I-V curves at different temperatures

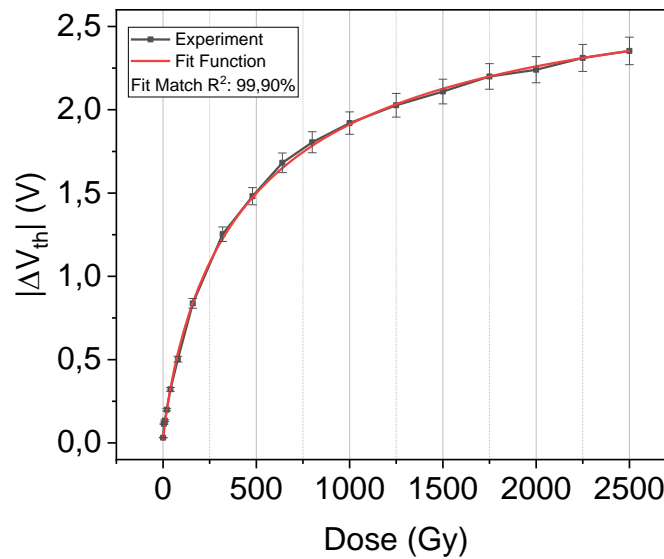

**Figure 3:** Calibration curve demonstrates the variation in  $V_{RC,th}$  during irradiation. The process is conducted at 20 °C using a Co-60 gamma source, with a dose rate of approximately 220 Gy/h. Error bar contains five distinct NürFETs measurements.

The NürFET is subjected to the forced current  $I_{RC}$  in the RC configuration. The voltage at the source, denoted as  $V_{RC,th}$ , is then measured, representing the RC-threshold-voltage. Essentially, any read-out current ( $I_{RC}$ ) exceeding  $1.0 \mu A$  can be selected, provided that the value remains constant after the onset of radiation exposure. For optimal temperature compensation, it is advisable to operate for an  $I_{RC}$  value between  $25-40 \mu A$  for R1, minimizing the impact of temperature variations as illustrated in Figure 2. Irradiation dose is determined by the change in threshold voltage resulting from charges trapped by radiation. A typical calibration curve under irradiation exposure is illustrated in Figure 3 and some features of NürFETs are listed in Table 3.

**Table 3:** Additional Information of NürFETs

Characteristics	Specification	Unit	Remarks
Initial Threshold Voltage in RC*	-6.5 to -4.0	Volt	Figure 2 @ $I_{RC} = 10\mu A$
Measurable Dose Range**	1.0 to 2500	Grays	Tested with Co-60 irradiation
Maximum sensitivity, $S_{max}$ ***	$7.6 \pm 0.28$	mV/Gy	@ 40 Grays at 20 °C
Fading	$3.4 \pm 0.4$	Percentage %	@ 20 °C in 5 days
Price****	60	Euro	Taxes and Shipping Excluded

\* The exact value will be provided prior to shipment in documentation that comes with ordered parts.

\*\*The NürFETs exhibits an extensive dynamic range, spanning from 1 Gy (100 rad) to 2500 Gy (250 krad) and beyond, with the possibility of further extension (up to 10 kGy) through additional calibration.

\*\*\* A fit function will be provide for the read-out electronics or calibration curve given below can be followed for accurate dose measurements

\*\*\*\* Please do not hesitate to inquire about prices for multiple orders. Please ask price of the unpackaged bare NürFET chips, if need.

## Package Dimensions (Unit: inch)

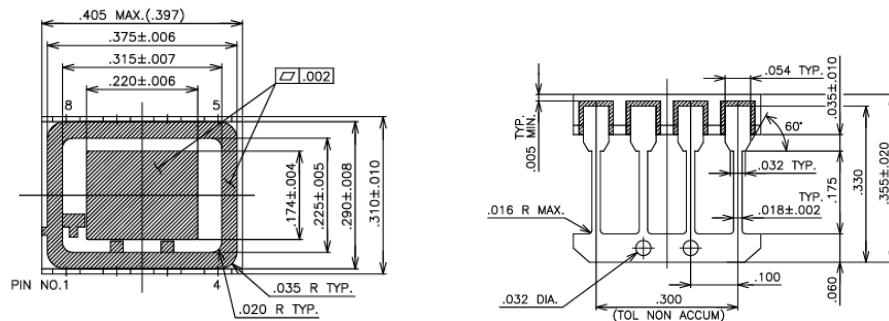

## Additions

Concerning the upper limit of dose range, the NürFET is capable of measuring doses exceeding 2.5 kGy (up to 10 kGy or 1000 krad). Nevertheless, the sensitivity diminishes with increasing dose, and the acceptability of this sensitivity loss depends on the specific requirements of the application.

The packaging tool is the empty 8 Lead Side Brazed with SSM P/N CSB00815 product code made by Kyocera.

Customers with requirements that differ significantly from the above conditions should contact [senolkaya@ibu.edu.tr](mailto:senolkaya@ibu.edu.tr) to discuss the best way to implement NürFETs for their specific applications